

**QUALITY CRIMPING
HANDBOOK**

Table of Contents

SECTION

- 1 Introduction to Crimp Technology
 - 2 Purpose
 - 3 Scope
 - 4 Definitions
 - 5 Associated Materials
 - 6 Procedures
 - 7 Measurement
 - 8 Crimp Process Control
 - 9 Troubleshooting
 - 10 Wire Gauge Chart
-

SECTION 1

INTRODUCTION TO CRIMP TECHNOLOGY

Developed to replace the need to solder terminations, crimping technology provides a high quality connection between a terminal and a wire at a relatively low applied cost. The methods for applying crimp terminations depend on the application and volume, and range from hand-held devices to fully automated systems.

The application methods include a basic hand tool, a press and die set, a stripper crimper, or a fully automatic wire processing system. However, no matter what method is used, the setup of each tool is critical for achieving a quality crimp.

Today, many OEM companies are using Statistical Process Control (SPC) to continuously improve their crimp terminations. Crimp termination is a complex process and to ensure consistent quality it is necessary to understand the variability and inter-relational interactions that the technology involves.

Without a thorough understanding of the crimping process, and all the factors that can affect it, the result may not meet expectations. The three key elements in the crimping process are the terminal, the wire, and the tooling.

Terminal

For most applications, it is not economically practical for connector manufacturers to design a terminal to accept one wire size, one wire stranding, and one insulation diameter (UL type). Most terminals accommodate many wire sizes, stranding, and a range of insulation diameters, and the terminals are designed to meet acceptable levels over this entire range.

Wire

The wire stranding and insulation type can vary widely within one wire size. For example, there is more than 18% more material in an 18 AWG by 19-strand wire than an 18 AWG by 16-strand wire. The insulation diameter of an 18 AWG wire can range from 1.78mm (.070") to over 4.57mm (.180"). Wire strands can be copper, tinned, over coated, or top coated. Wire insulation materials, thickness, and durometers vary from application to application.

Tooling

What type of tooling does the application require? Does the application require hand stripping of the wire or does the volume dictate an automatic wire-stripping machine? Does the application and volume require hand tools, press and die, or fully automatic wire process machines? Crimping with a manual hand tool, semi-automatic press and die, or fully automatic wire processor, all involve different levels of variability. The terminal, wire, and type of application tooling all affect the quality of the completed terminations.

SECTION 2

PURPOSE

This handbook provides general guidelines and procedures for understanding and achieving acceptable crimp terminations. A glossary in Section 4 lists common terms and definitions. Section 5 lists the tools that are necessary to take accurate measurements and evaluate the crimp's acceptability.

The tooling setup is critical in determining the quality of the finished crimp. The attributes that need to be considered include crimp height, conductor brush, bell mouth, and cut-off tab and strip length and insulation position. Variability in one or more of these attributes can reduce the measured pull force. It can be difficult to establish acceptable variability limits because the attributes all interact with one another.

For example, a track adjustment for bell mouth also will change the cut-off tab length and the insulation wire position while strip length and wire locations affect the conductor brush and insulation position. Adjusting the insulation crimp height may result in a slight change to the conductor crimp height measurement. It may be necessary for the setup person to make multiple adjustments before establishing an optimal setup.

The order the setup is done may help reduce the number of repetitions required for an optimum setup. Section 6 has a flowchart for a process setup while Section 9 is a troubleshooting guide for common problems. Using Statistical Process Control (SPC) during the crimping process can help minimize the amount of defects. Section 8 provides a general explanation of the benefits of using SPC.

This handbook is structured so that parts, or all, of its contents can be used as a procedural guide for ISO requirements.

SECTION 3

SCOPE

primarily in semiautomatic or automatic wire processing termination methods.

The handbook's contents may slightly differ from other connector manufacturers' guidelines or individual company procedures.

This handbook provides a basic overview of what to look for in an acceptable crimp. It is not intended to replace individual product and/or tooling specifications.

Individual terminals or applications may have special requirements. Tooling limitations also may not permit an attribute to be adjusted to meet optimum requirements.

SECTION 4

DEFINITIONS

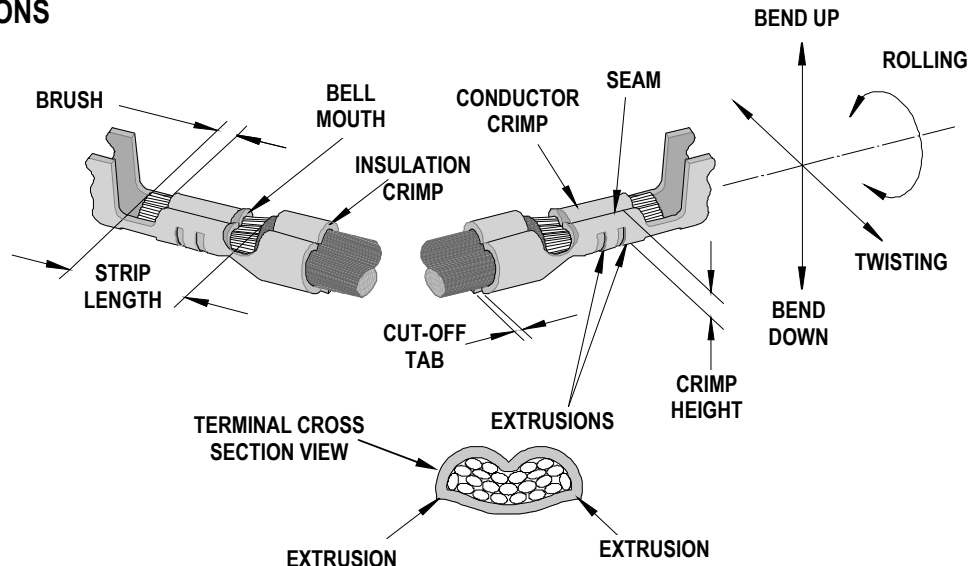

Figure 4-1

mechanical compression occurs over the full length of the conductor crimp. The conductor brush should not extend into the contact area.

Anatomy of a Crimp Termination (Figure 4-1)

- **Bell Mouth (Flare)**
 The flare that is formed on the edge of the conductor crimp acts as a funnel for the wire strands. This funnel reduces the possibility that a sharp edge on the conductor crimp will cut or nick the wire strands. As a general guideline, the conductor bell mouth needs to be approximately 1 to 2 times the thickness of the terminal material. *
- **Bend Test**
 One way to test the insulation crimp is by bending the wire several times and then evaluating the movement of the insulation and wire strands. As a rule, the insulation crimp should withstand the wire being bent 60 to 90 degrees in any direction, several times. Use care when working with small wire sizes so the wire at the back of the insulation crimp does not shear.
- **Conductor Brush**
 The conductor brush is made up of the wire strands that extend past the conductor crimp on the contact side of the terminal. This helps ensure that
- **Conductor Crimp**
 This is the metallurgical compression of a terminal around the wire's conductor. This connection creates a common electrical path with low resistance and high current carrying capabilities.
- **Conductor Crimp Height**
 The conductor crimp height is measured from the top surface of the formed crimp to the bottom radial surface. Do not include the extrusion points in this measurement (See Figure 4-1). Measuring crimp height is a quick, non-destructive way to help ensure the correct metallurgical compression of a terminal around the wire's conductor and is an excellent attribute for process control. The crimp height specification is typically set as a balance between electrical and mechanical performance over the complete range of wire stranding and coatings, and terminal materials and plating. Although it is possible to optimize a crimp height to individual wire stranding and terminal plating, one crimp height specification is normally created.

*Consult individual terminal specification requirements

■ **Cut-off Tab Length**

This material protrudes outside the insulation crimp after the terminal is separated from the carrier strip. As a rule, the cut-off tab is approximately 1.0 to 1.5 times terminal material thickness. * A cut-off tab that is too long may expose a terminal outside the housing or it may fail electrical spacing requirements. In most situations, a tool is set-up to provide a cut-off tab that is flush to one material thickness.

■ **Extrusions (Flash)**

These small flares form on the bottom of the conductor crimp resulting from the clearance between the punch and anvil tooling. If the anvil is worn or the terminal is over-crimped, excessive extrusion is the results. An uneven extrusion may also result if the punch and anvil alignment is not correct, if the feed adjustment is off, or if there is insufficient/excessive terminal drag.

■ **Insulation Crimp (Strain Relief)**

This is the part of the terminal that provides wire support for insertion into the housing. It also allows the terminal to withstand shock and vibration. The terminal needs to hold the wire as firmly as possible without cutting through to the conductor strands. The acceptability of an insulation crimp is subjective and depends on the application. A bend test is recommended to determine whether the strain relief is acceptable for each particular application.

■ **Insulation Crimp Height**

Molex does not specify insulation crimp heights because of the wide variety of insulation thickness, material, and hardness. Most terminals are designed to accommodate multiple wire ranges. Within the terminal's range, the strain relief may or may not completely surround the diameter of the wire. This condition will still provide an acceptable insulation crimp for most applications.

1. A large strain relief should firmly grip at least 88% of the wire.
2. A smaller strain relief should firmly grip at least 50% of the wire and firmly hold the top of the wire.

To evaluate the insulation crimp section, cut the wire flush with the back of the terminal. Once the optimum setting for the application is determined, it is important to document the insulation crimp height. Then, as part of the setup procedure, the operator can check the crimp height.

■ **Insulation Position**

This is the location of the insulation in relation to the transition area between the conductor and insulation crimps. Equal amounts of the conductor strands and insulation needs to be visible in the transition area. The insulation position ensures that the insulation is crimped along the full length of the insulation crimp, and that no insulation is crimped under the conductor crimp. The insulation position is set by the wire stop and strip length for bench applications. For automatic wire processing applications, the insulation position is set by the in/out press adjustment.

■ **Strip Length**

The strip length is determined by measuring the exposed conductor strands after the insulation is removed. The strip length determines the conductor brush length when the insulation position is centered.

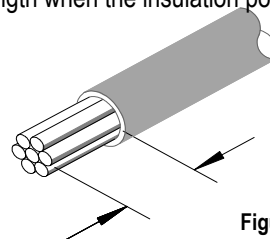

Figure 4-2

*Consult individual terminal specification requirements

■ **Process**

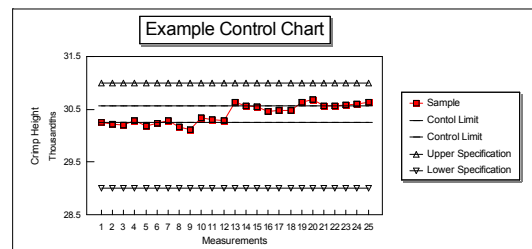

Figure 4-3

The combination of people, equipment, tooling, materials, methods, and procedures needed to produce a crimp termination. Process Control is used to track attributes over time to aid in the detection of change to

the process. Detecting a process change when it happens helps prevent many thousands of bad crimps.

■ **Pull Force Testing**

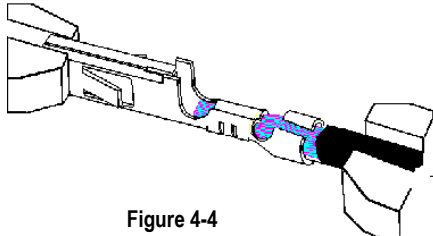

Figure 4-4

Pull force testing is a quick, destructive way to evaluate the mechanical properties of a crimp termination.

Pull force testing results out of allowed range are good indicators of problems in the process. Cut or nicked strands in the stripping operation, lack of bell mouth or conductor brush, or incorrect crimp height or tooling will reduce pull force tests results. Wire properties and stranding, and terminal design (material thickness and serration design), also can increase or decrease the value of the results of a pull force levels.

If results of a pull force tests are within an allowed range, it assures that proper crimp force has been applied during crimping. It is crucial as, when making a crimp, enough force must be applied to break down the layer of non-conductive oxides that may build up on the stripped conductor and the tinning on the inside of the terminal grip. This is

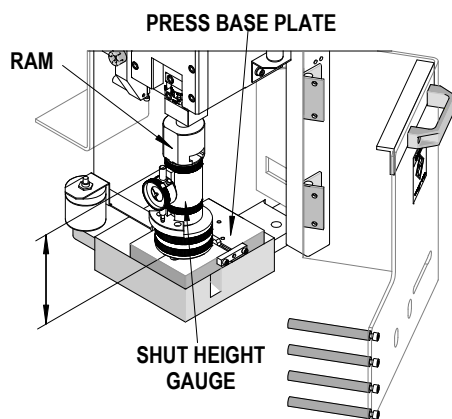

Figure 4-5

necessary to provide a good metal-to-metal contact. If this does not occur, resistance can increase. Over-crimping a crimp termination will reduce the circular area of the conductor and increase resistance.

■ **Shut Height**

This is the distance (at bottom dead center on a press) from the tooling mounting base plate to the tooling connection point on the ram of the press.

■ **Terminal Position**

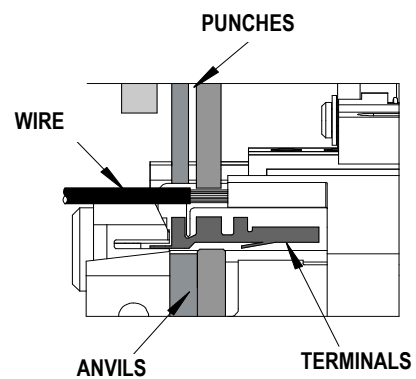

Figure 4-6

The terminal position is set by the alignment of the terminal to the forming punch and anvils, and the carrier strip cut-off tooling. The tool set-up determines conductor bell mouth, cut-off tab length, and terminal extrusions

SECTION 5

ASSOCIATED MATERIALS

- **Caliper**

A gauge, consisting of two opposing blades. It used for measuring linear dimensional attributes.

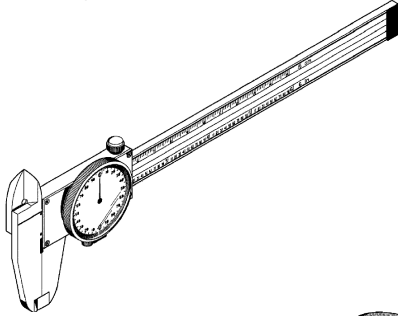

- **Eye Loupe**

This is an image magnification tool, normally 10 times power or greater, which is used in the aid visual evaluation of a crimp termination.

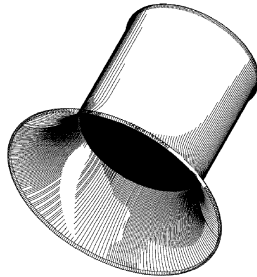

- **Crimp Micrometer**

This is a micrometer specifically designed to measure crimp height. The measurement is taken in the center of the crimp so the conductor bell mouth does not influence it. It has a thin blade that supports the top of the crimp while a pointed section determines the bottom radial surface.

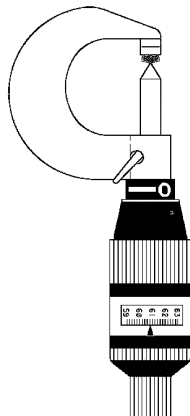

- **Ruler (Pocket Scale)**

This is used to measure the length of bell mouth, cut-off tab, conductor brush, strip length and estimate wire position. The recommended maximum resolution is 0.50mm (.020").

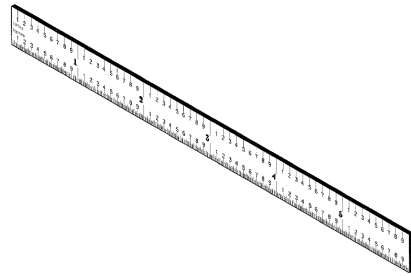

- **Pull Tester**

A device used to determine the mechanical strength of a crimp termination. Most pull testing is done with a device that clamps the wire, pulls at a set speed, and measures force by means of a load cell. A pull tester also can be as simple as hanging fixed weights on the wire for a minimum of one minute.

- **Toolmaker's Microscope**

This is used for close visual evaluation and statistical measurement of bell mouth, cut-off tab, conductor brush, wire position and strip length.

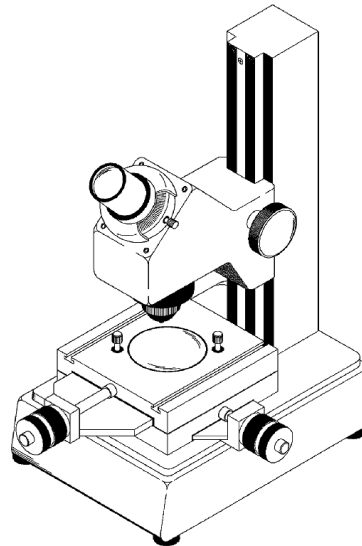

SECTION 6

PROCEDURES

Tool Setup (Reference Procedures Flow Chart)

1. Check that tooling is clean and not worn. If necessary, clean and replace worn tooling.
2. Disconnect power to the press and remove guarding devices.
3. Install the appropriate tooling into the press.
4. Load terminals into the tooling so that the first terminal is located over the anvil.
5. Manually cycle the press to help ensure a complete cycle can be made without interference. If it cannot, remove tooling and check press shut height. Go to procedure 3.
6. Check that the tooling is aligned. Check the impression on the bottom of the crimp that was made by the anvil tooling. Check that the extrusions and crimp form are centered. If not, align tooling and go to procedure 5.
7. Check that the terminal feed locates the next terminal over the center of the anvil tooling. If not, adjust terminal feed and feed finger and go to procedure 5.
8. Re-install all safety devices that were removed during the set-up. **(Follow all safety requirements listed in individual press and/or tooling manuals.)**
9. Crimp sample terminals under power.
10. Evaluate cut-off tab length and conductor bell mouth. If adjustment is necessary, disconnect power to the press and remove guarding. Adjust track position. Manually cycle the press and check the feed finger for feed location, go to procedure 7.
11. Evaluate conductor brush. If adjustment is necessary, disconnect power to the press and remove guarding. Adjust wire stop for bench applications or press position on automatic wire processing equipment. Go to procedure 8.
12. Evaluate insulation position. If necessary, adjust strip length, crimp new samples, and go to procedure 11.
13. Loosen insulation crimp height.
14. Crimp sample terminals.
15. Measure conductor crimp height and compare to specification. If necessary, disconnect power and remove guarding. Adjust conductor crimp height, install guards, connect power, and go to procedure 14.
16. Perform a pull force test. Refer to troubleshooting (Section 9) if this test fails.
17. Adjust insulation crimp.
18. Crimp sample terminals.
19. Evaluate insulation crimp. If necessary, disconnect power and remove guarding. Adjust insulation crimp height, install guards, connect power, and go to procedure 18.
20. Measure crimp height and compare to specification. If necessary, disconnect power and remove guarding. Adjust conductor crimp height, install guards, connect power, and go to procedure 18.
21. Document measurements.

Please Work Safely At All Times.

PROCEDURES FLOW CHART

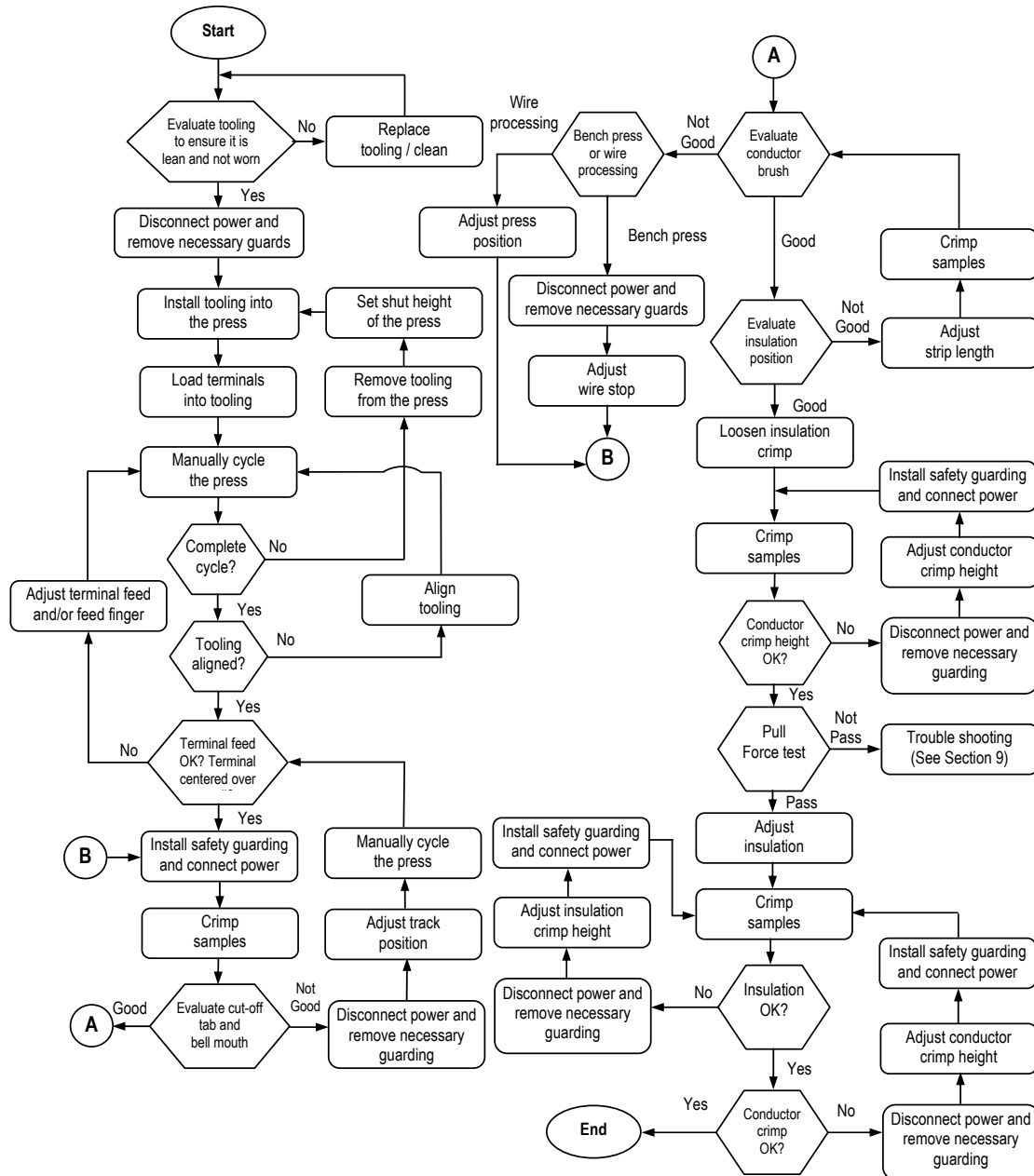

SECTION 7

MEASUREMENT

Pull Force Testing

1. Cut wire length to approximately 150mm (6") long.
2. Strip one end to 13mm (.50"), or long enough so no wire insulation is under the insulation grip, or loosen the insulation crimp so it has no grip on the insulation of the wire.
3. Terminate the appropriate terminal to the wire to the nominal crimp height.
4. Visually inspect the termination for bell mouth, wire brush and cut strands.
5. Set pull tester to 254mm per minute (1.00" per minute). For most applications, a higher rate will not have a significant impact on the data. The slower rate prevents a sudden application of force or jerking that snaps strands. Verify higher pull rates with data taken at 1.00" per minute.
6. If necessary, knot the un-terminated end of the wire (If insulation slips on wire).
7. Regardless of pull tester type, both wire and terminated end must be securely clamped. (Note: Clamp terminal contact interface, do not clamp conductor crimp)
8. Activate pull test.
 - a. Record pull force readings. A minimum of five pull force measurements should be done to confirm each set-up. A minimum of 25 readings should be taken for determining process capability.
 - b. Compare lowest reading to minimum pull force specification.

Note: High variability and lower value of C_{pk} (see section 8 for explanation of C_{pk}) are common when two wires are crimped together. The variability is due to more variation in conductor brush, conductor bell mouth and fewer strands of one wire being in contact with the serrations on the terminal barrel. A double wire crimp is considered no better than the smallest wire crimped. Higher pull force readings can be seen if both wires are gripped and pulled exactly together. Pulling each wire individually will result in a much lower pull force reading. If both wires are of the same size,

the top wire will normally result in a lower reading than the bottom wire due to the effects of the terminal serrations.

Wire Chart

Note: Pull force has only a minimum specification. For C_{pk} calculations, the average reading is assumed nominal and the upper specification limit is set so C_p and C_{pk} are equal. High pull force readings that increase the standard deviation can lower C_{pk} even if the mean and lowest reading are increased.

Test Values for Pull Force Test			
UL486A			
Size of Conductor		Pullout Force*	
AWG	mm ²	Lbf	N
30	0.05	1.5	6.7
28	0.08	2	8.9
26	0.13	3	13.4
24	0.20	5	22.3
22	0.324	8	35.6
20	0.519	13	57.9
18	0.823	20	89.0
16	1.31	30	133.5
14	2.08	50	222.6
12	3.31	70	311.5
10	5.261	80	356.0
8	8.367	90	400.5

*Consult individual specifications

Crimp Height Testing

1. Complete tool set-up procedure.
2. Crimp a minimum of five samples.
3. Place the flat blade of the crimp micrometer across the center of the dual radii of the conductor crimp. Do not take the measurement near the conductor bell mouth.
4. Rotate the micrometer dial until the point contacts the bottom radial surface. If using a caliper, be certain not to measure the extrusion points of the crimp.
5. Record crimp height readings. A minimum of five crimp height readings is necessary to confirm each set-up. A minimum of 25 readings is necessary to determine capability.
6. Check crimp height every 250 to 500 parts throughout the run.

Note: Crimp height is usually control charted because it is a quick, nondestructive measurement and is critical for the termination's electrical and mechanical reliability. There are three primary purposes for control charting. One, the number of setup samples is normally small, and its statistical value is limited. Two, since special cause/effects on a process are irregular and unpredictable; it is necessary to have a means of catching changes in the process as soon as they occur. This prevents having to scrap thousands of terminations after the run is over. Three and this is most important, the data is necessary to assess and improve the crimp process.

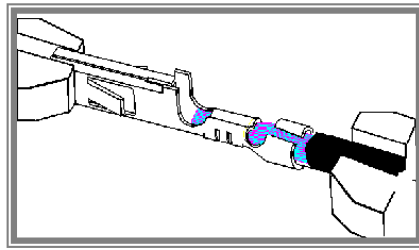

Figure 7-1
PULL TESTING

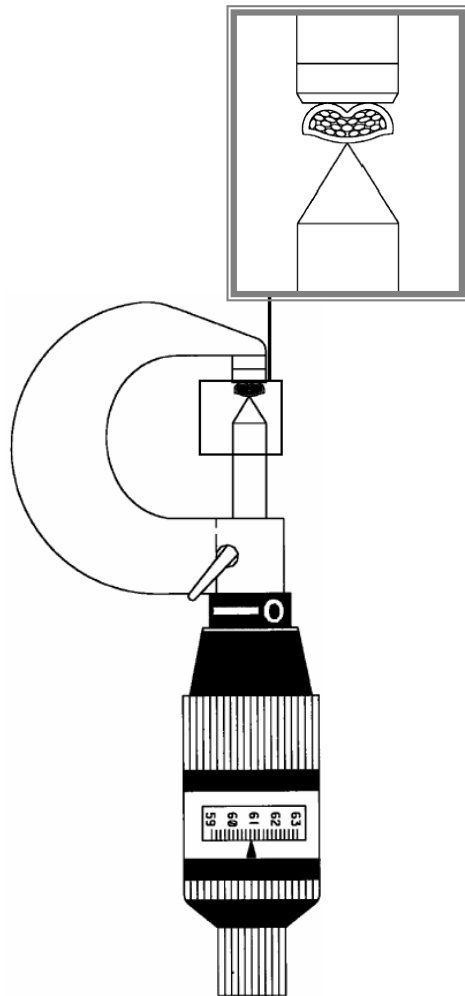
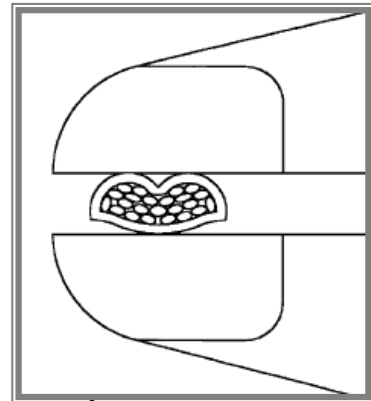

Figure 7-2
CRIMP MICROMETER

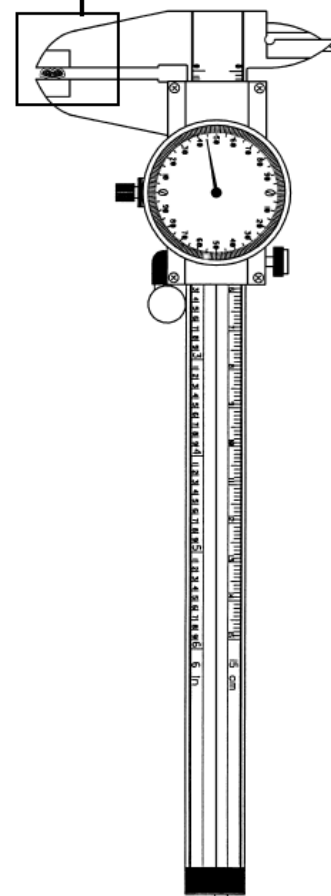

Figure 7-3
CALIPER

SECTION 8

CRIMP PROCESS CONTROL

The crimp process is the interaction of a terminal, wire, tooling, personnel, methods and procedures, and environmental attributes. When this process is controlled, it will produce a quality termination. Quality control is an important part of quality crimping. It should not take excessive setup or inspection time to do, and it can save a harness manufacturer thousands of dollars in potential rework or re-manufacturing.

Variability is the slight change that occurs from crimp to crimp. There are two types of variability, common or special. Common causes of variation affect the process uniformly and are the result of many small sources. Common variability is inherent tolerances within a reel of wire or terminals. Common variability also is created by the natural tolerances of the stripping and crimping machines.

Reducing variability at the common level typically has to come from changes to the wire, terminal, and tooling manufacturer.

Special causes of variation occur irregularly and unpredictably. Without checks throughout a run, having a tool become loose after the first hundred crimps or a jam resulting from a damaged tool may be undetected until thousands of crimps are made.

Process Capability

Before putting a new crimping tool in production, Molex recommends that each customer do a capability study, using the specific wire that will be used in its process. A capability study, which is based on the assumption of a normal distribution (bell-type curve), estimates the probability of a measurement being outside of specification.

Capability			
C _{pk}	+/- Sigma	% Yield	PPM*
0.67	2	95.45	45,500
1	3	99.73	2,699
1.33	4	99.99	63
1.67	5	99.99+	0.57
2	6	99.99++	0

* PPM - Parts per million potential defects.

A 25 piece minimum sample needs to be taken from the crimping process. Calculate the average and standard deviation for the sample. A capability index is defined by the formula below. C_p may range in value from zero to infinity, with a larger value indicating a more capable process. A value greater than 1.33 is considered acceptable for most applications. C_p is calculated with the following formula.

$$\frac{\text{Tolerance}}{6 \times \text{Standard Deviation}}$$

The C_{pk} index indicates whether the process will produce units within the tolerance limits. C_{pk} has a value equal to C_p if the process is centered on the mean of specification; if C_{pk} is negative, the process mean is outside the specification limits; if C_{pk} is between 0 and 1 then some of the 6 sigma spread falls outside the tolerance limits. If C_{pk} is larger than one, the 6-sigma spread is completely within the tolerance limits. C_{pk} is calculated with the lesser of the following formulas:

$$\frac{(\text{USL} - \text{Mean})}{3 \times \text{Standard Deviation}} \quad \frac{(\text{Mean} - \text{LSL})}{3 \times \text{Standard Deviation}}$$

USL = Upper Specification Limit, LSL = Lower Specification Limit

Six sigma is a goal of many companies because it represents virtually zero defects. The ability of a company to achieve a six-sigma level depends on the amount of common variability in its process. For example, hand stripping the wire produces more variability than a stripping machine; crimping hand tools produce more variability than a press and die set, and bench terminations produce more variability than a wire-processing machine.

A part of the variability in crimping will result from the type of instruments that are used to measure the parts and the operator's ability to repeat the measurement. A crimp micrometer will measure more accurately than a dial caliper. An automatic pull force system will measure better than a hook type scale. It is important that the measurement gauge has enough resolution.

Two operators may measure the same part differently, or the same operator may measure the part differently when using two types of gauges. Molex recommends a gauge capability study to identify what part of the variability is coming from measurement error. Micro-terminals crimped to small wire sizes need a tight crimp height range to maintain pull force. The variability from measurement error can keep C_{pk} values low.

The capability of the crimping tools needs to be re-confirmed if the production data is significantly different from the capability study.

Production

Before the tool is ready for production, the level of capability needs to be established. Many harness manufacturers run only a few hundred or few thousand wires at one time. In this case, it is not practical or economical to run a twenty-five-piece capability with every set-up.

Visual Inspection

It needs to be standard operating procedure for the operator to manually fan each bundle of crimped wires and visually check bell mouth, conductor brush, insulation position, cut-off tab length, and insulation crimp.

Control Charting

Crimp height is typically control charted because it is a quick nondestructive measurement and is critical for the termination's electrical and mechanical reliability. There are three primary purposes for control charting. One, the number of setup samples is usually small, with limited statistical value. Two, since special cause effects on a process are irregular and unpredictable; it is necessary to be able to catch changes in the process as soon as they occur. This prevents thousands of terminations from being scrapped after the run is over. Three, and most important, this data is necessary to assess and improve the crimp process.

Once the tooling process is setup and the wire size does not change, keep one control chart for wire color changes, wire length changes, terminal material

changes, or setup adjustments. Record the data point on the chart before making a crimp height adjustment. If data is recorded after each adjustment, the process is likely to assume control and provide little data for improving the process. The operator needs to make as many notes as possible on the chart. The only truly effective and economically sensible way to manage a manufacturing process is to understand, monitor and reduce sources of variability that are inherent to the process itself. Every minute required for setup or adjustments is unproductive.

What does this sample chart tell us?

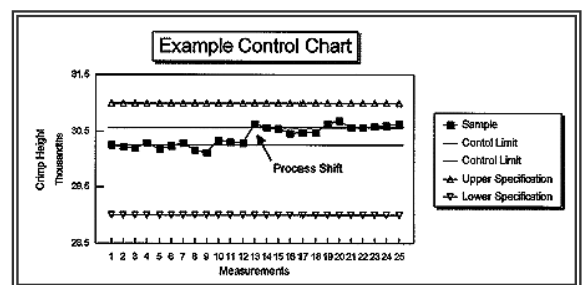

X and R Chart

$$\text{Control limit for sample of } 5 = \text{Avg} (\text{Avg of 5 readings}) + .577 \times \text{Avg} (\text{Ranges})$$

It indicates that a process shift occurred between measurement 12 and 13. This type of shift could occur due to a change in wire, a change in terminal lots, a jam in the machine that damaged the tooling, a change in operators, or an adjustment to the insulation crimp. Since the measurements are still within specification, would you stop production to adjust crimp height?

A shift in the process due to a change in material may warrant a crimp height adjustment. A shift after a jam would not indicate an adjustment, but a close evaluation of the tooling. A shift in the process between operators would not indicate an adjustment, but an evaluation of measurement capability. The purpose of a control chart is to identify what caused the shift in process to determine if an adjustment to the process is needed.

SECTION 9

TROUBLESHOOTING

Wire Preparation

Symptom	Cause	Solution
Irregular insulation cut (Figure 9-1)	Worn tooling	Replace tooling
	Wire cut depth too shallow	Adjust cut depth
Cut or nicked strands (Figure 9-2)	Damaged tooling	Replace tooling
	Cut depth too deep	Adjust cut depth
	Conductor not on wire center	Contact wire supplier
Irregular conductor cut-pulled strands (Figure 9-3)	Worn tooling	Replace tooling
	Wire cut depth too shallow	Adjust cut depth
Wire length variability too high (Figure 9-4)	Wire drive rollers/belts worn	Replace belts/rollers
	Insulation durometer too hard	Increase drive pressure
	Wire straightener too loose or tight	Adjust wire straightener
Wrong strip length (Figure 9-4)	Incorrect setup	Re-setup tooling

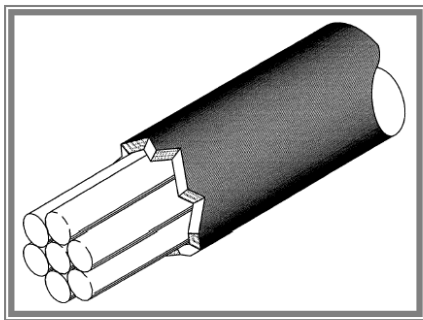

**Figure 9-1
IRREGULAR INSULATION CUT**

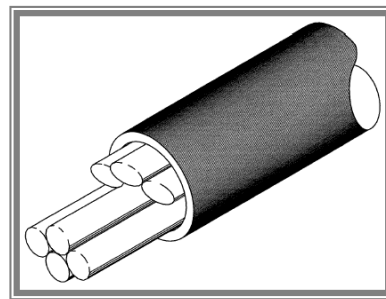

**Figure 9-2
CUT STRANDS**

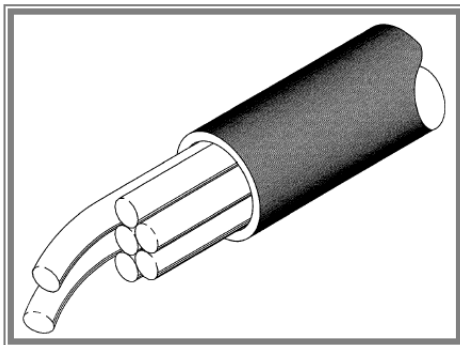

**Figure 9-3
PULLED STRANDS**

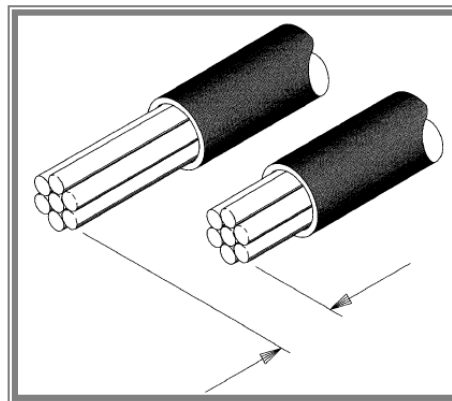

**Figure 9-4
WIRE LENGTH VARIABILITY OR WRONG STRIP LENGTH**

Bell Mouth and Cut-off Tab Length

Symptom	Cause	Solution
Low pull force (Figure 9-6 and 9-7)	Excessive bell mouth, no cut-off tab	Adjust track position for small cut-off tab
	Excessive bell mouth, cut-off tab alright	Check for worn or incorrect punch tooling and replace
Cut or nicked strands (Figure 9-8)	No bell mouth and/or excessive cut-off tab	Adjust track position
		Check for camber in terminal strip
Long cut-off tab (Figure 9-9)	Good bell mouth and excessive cut-off tab	Check for worn cut-off and replace if necessary
		Check for worn punch tooling, replace, and re-adjust track

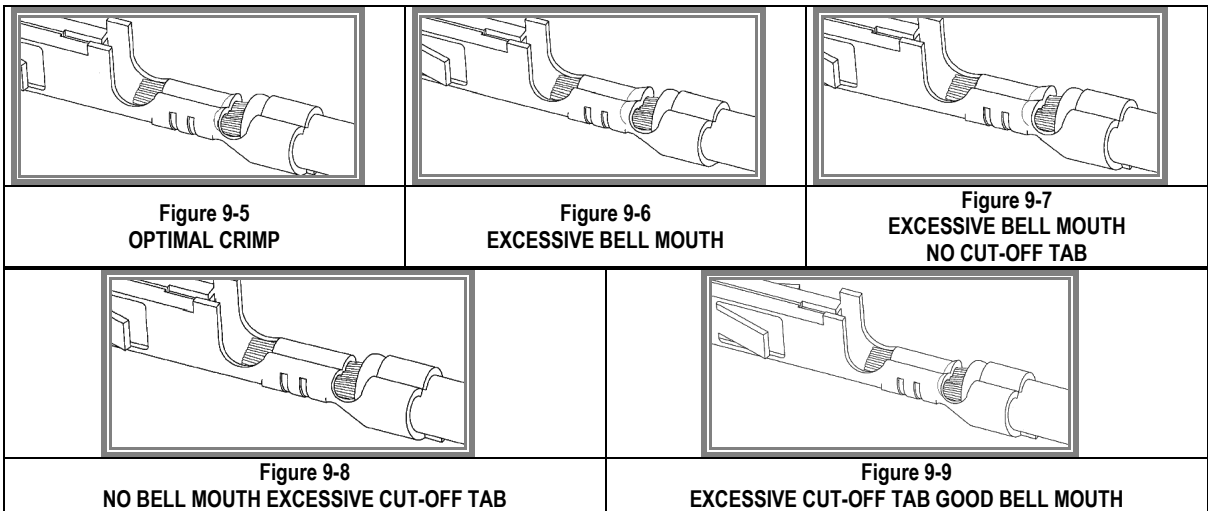

Conductor Brush and Insulation Position

Symptom	Cause	Solution
Insulation under conductor crimp, good conductor brush (Figure 9-10)	Strip length too short	Check specification, adjust strip length longer
Insulation under conductor crimp, long conductor brush length (Figure 9-11)	Bench top crimping - Wire stop position incorrect	Adjust wire stop to center of transition area
	Wire Processing – Press position incorrect	Adjust press position away from wire
Insulation under conductor crimp, short or no conductor brush (Figure 9-12)	Strip length too short	Check specification, adjust strip length longer
		Re-adjust wire stop position for bench top applications OR re-adjust press position for wire processing applications
Insulation edge centered in transition area, conductor brush too long (Figure 9-13)	Strip length too long	Check specification, adjust strip length shorter
	Irregular wire cut-off or strands pulled from insulation bundle	Re-adjust wire stop position for bench top applications OR re-adjust press position for wire processing applications
Insulation edge centered in transition area, conductor brush too short (Figure 9-14)	Strip length too short	Check specification, adjust strip length longer
		Re-adjust wire stop position for bench top applications OR re-adjust press position for wire processing applications
Insulation edge under insulation crimp, Good or long conductor brush (Figure 9-15)	Strip length too long	Check specification, adjust strip length shorter
		Re-adjust wire stop position for bench top applications OR re-adjust press position for wire processing applications
Insulation edge under insulation crimp, short or no conductor brush (Figure 9-16)	Bench top crimping - Wire stop position incorrect	Adjust wire stop to center of transition area
	Wire processing - Press position incorrect	Adjust press position away from wire
	Verify operators wire placement ability	Operator training, reduce crimping rate

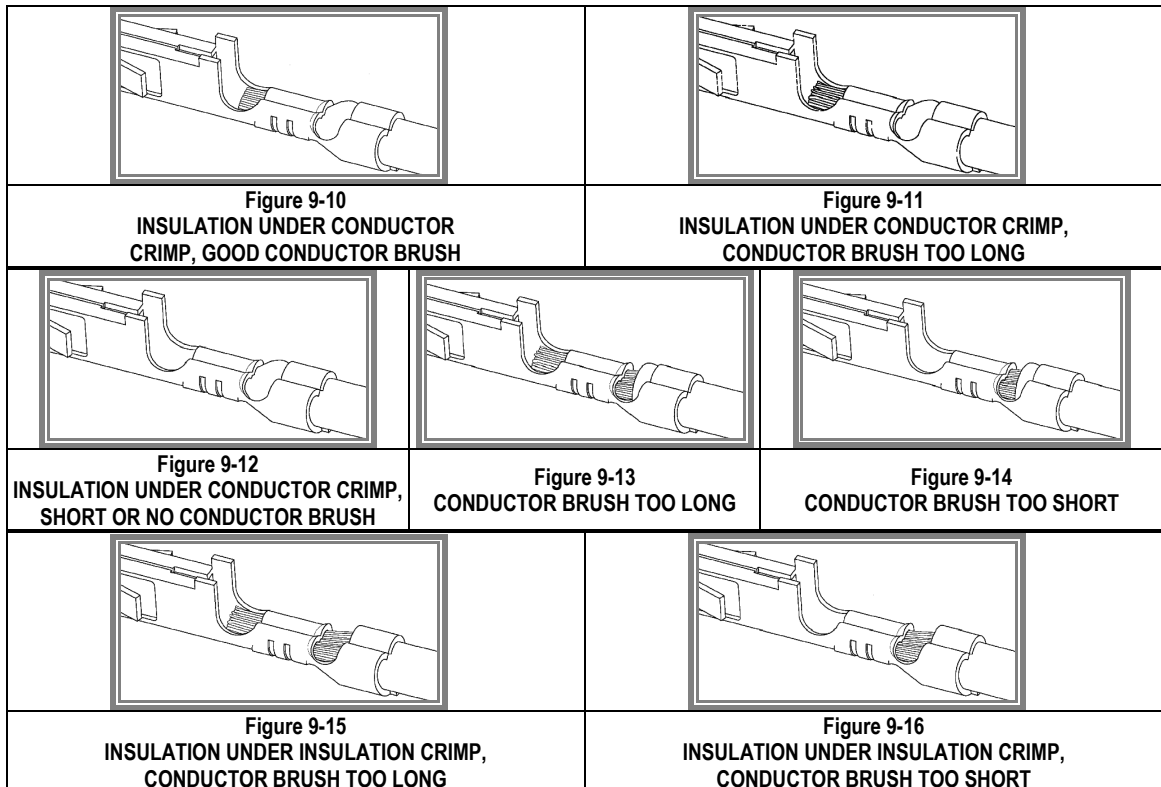

Insulation Crimp

Symptom	Cause	Solution
Terminal surrounds less than 88% of a large diameter wire (Figure 9-21)	Crimp too loose, not enough terminal insulation barrel	Tighten insulation crimp height Evaluate terminal
Terminal contacts less than 50% of a small diameter wire (Figure 9-22)	Too much terminal insulation barrel	Evaluate terminal
Insulation crimp barrels cut through insulation into conductor strands (Figure 9-23)	Crimp too tight	Adjust insulation crimp height*
Insulation not firmly gripping insulation, fails bend test (Figure 9-24)	Crimp too loose	Adjust insulation crimp height tighter

* Inexpensive hand tools provide no adjustment for the insulation crimp. A hand tool is intended for low volume applications. Although you are not able to adjust the insulation crimp on a hand tool, an insulation crimp, which pierces the insulation, may still be considered acceptable for many applications. This criterion only applies to hand tools due to their low speed crimp cycle. If the insulation crimp pierces the insulation, the wire strands tend to move aside without damage.

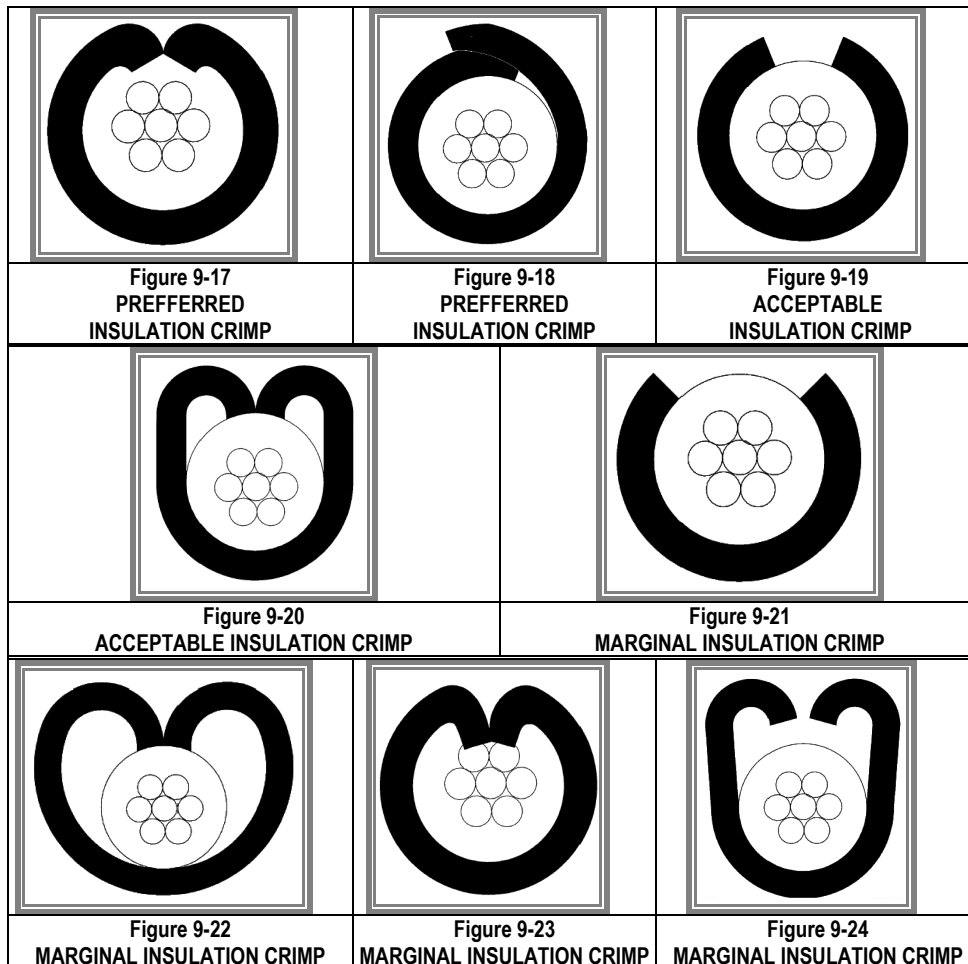

Crimp Height

Symptom	Cause	Solution
Crimp height off target (Figure 9-26)	Changed wire type vendor or stranding	Adjust tooling back to target
	Changed insulation color or durometer	
	Changed crimp tooling	
	Changed crimp press (shut height)	
	Changed press type (manufacturer)	
	Changed terminal reel (lot code)	
	Changed tooling set-up	
Crimp height variability too high (Figure 9-27)	Damaged or worn tooling	Replace tooling
	Wire variability	Inspect incoming product
	Terminal variability	
	Damaged, loose or worn tooling	Tooling replacement or tightening
	Measurement error	Gauge capability analysis
	Terminal spring-back too great, over crimping	Crimp height adjustment
Cut or missing wire strands	Stripping process adjustment	

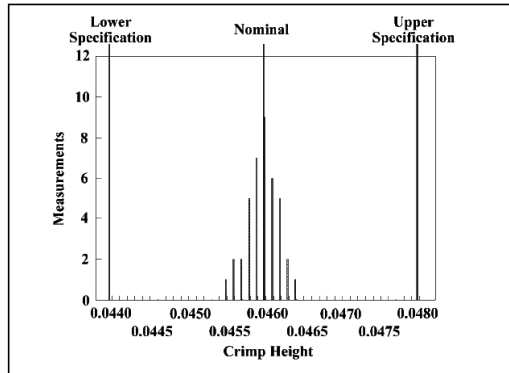

Figure 9-25
OPTIMAL CRIMP HEIGHT CHART

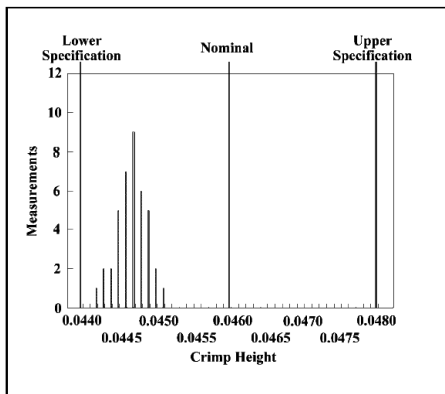

Figure 9-26
CRIMP HEIGHT OFF TARGET

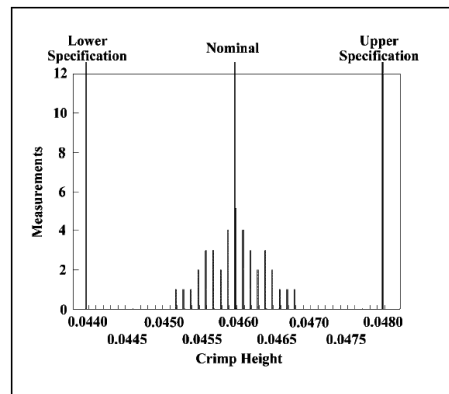

Figure 9-27
CRIMP HEIGHT VARIABILITY TOO HIGH

Pull Force

Symptom	Cause	Solution
Wire breaks before conductor crimp - low pull force (Figure 9-29)	Cut or nicked strands	Check the stripping process
	Crimp height too low	Adjust crimp height
	Small or no bell mouth	Adjust tooling track
	Insulation crimp through insulation wall	Raise insulation crimp height
Wire pulls out of conductor grip - low pull force (Figure 9-29)	Crimp height too high	Adjust crimp height
	Small or no conductor brush	Increase strip length
	Conductor bell mouth too big	Adjust tooling track
	Gold terminal application	Evaluate the terminal application
	Terminal material thickness too small	
	Light serrations on terminal	Contact your local sales engineer

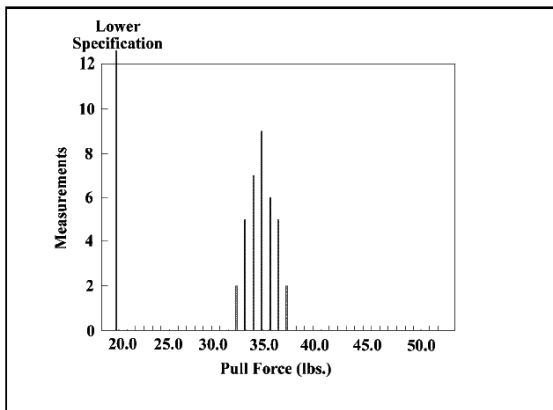

Figure 9-28
OPTIMAL PULL FORCE CHART

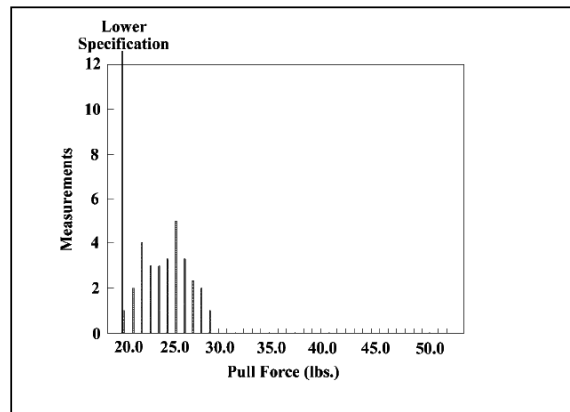

Figure 9-29
LOW PULL FORCE CHART

SECTION 10

Wire Gauge Chart

AWG	Wire Area		Stranding		Wire Diameter		Circular	Wire Break	
	Sq. mm	Sq. inch	No.	Dia.	mm	In.	Mills	N	Lbf.
8	8.302	.01287	1	.1280	3.25	.128	16384	2175.00	489.0
8	7.820	.01212	19	.0285	3.68	.145	15433	2048.72	460.6
8	7.955	.01233	49	.0179	3.73	.147	15700	2084.21	468.6
8	8.605	.01334	133	.0113	3.73	.147	16983	2254.49	506.9
8	8.513	.01319	168	.0100	3.73	.147	16800	2230.22	501.4
8	8.424	.01306	665	.0020	3.73	.147	16625	2206.99	496.2
10	5.261	.00816	1	.1019	2.59	.102	10384	1378.44	309.9
10	4.740	.00735	37	.0159	2.92	.115	9354	1241.75	279.2
10	5.006	.00776	49	.0142	2.95	.116	9880	1311.63	294.9
10	5.320	.00825	105	.0100	2.95	.116	10500	1393.89	313.4
12	3.308	.00513	1	.080	2.05	.081	6529	866.69	194.8
12	3.632	.00563	7	.0320	2.44	.096	7168	951.56	213.9
12	3.085	.00478	19	.0179	2.36	.093	6088	808.16	181.7
12	3.294	.00511	65	.0100	2.41	.095	6500	862.88	194.0
12	3.3118	.00514	165	.0063	2.41	.095	6549	869.37	195.5
14	2.082	.00323	1	.0641	1.63	.064	4109	545.45	122.6
14	2.270	.00352	7	.0253	1.85	.073	4481	594.81	133.7
14	1.941	.00301	19	.0142	1.85	.073	3831	508.59	114.3
14	2.078	.00322	41	.0100	1.85	.073	4100	544.28	122.4
14	2.112	.00327	105	.0063	1.85	.073	4167	553.24	124.4
16	1.308	.00203	1	.0508	1.30	.051	2581	342.58	77.0
16	1.433	.00222	7	.0201	1.52	.060	2828	375.43	84.4
16	1.229	.00191	19	.0113	1.47	.058	2426	322.07	72.4
16	1.317	.00204	26	.0100	1.50	.059	2600	345.15	77.6
16	1.307	.00203	65	.0063	1.50	.059	2580	342.48	77.0
16	1.330	.00206	105	.0050	1.47	.058	2625	348.47	78.3
18	.823	.00128	1	.0403	1.02	.040	1624	215.60	48.5
18	.897	.00139	7	.0159	1.22	.048	1770	234.93	52.8
18	.811	.00126	16	.0100	1.19	.047	1600	212.40	47.8
18	.963	.00149	19	.0100	1.24	.049	1900	252.23	56.7
18	.825	.00128	41	.0063	1.19	.047	1627	216.03	48.6
18	.823	.00128	65	.0050	1.19	.047	1625	215.72	48.5
20	.519	.00080	1	.0320	.81	.032	1024	135.94	30.6
20	.563	.00087	7	.0126	.97	.038	1111	147.53	33.2
20	.507	.00079	10	.0100	.89	.035	1000	132.75	29.8
20	.616	.00096	19	.0080	.94	.037	1216	161.43	36.3
20	.523	.00081	26	.0063	.91	.036	1032	136.99	30.8
20	.519	.00081	41	.0050	.91	.036	1025	136.07	30.6
22	.324	.00050	1	.0253	.64	.025	640	84.97	19.1
22	.355	.00055	7	.0100	.76	.030	700	92.93	20.9

Quality Crimp Handbook

AWG	Wire Area		Stranding		Wire Diameter		Circular	Wire Break	
	Sq. mm	Sq. inch	No.	Dia.	mm	In.	Mills	N	Lbf.
22	.382	.00059	19	.0063	.79	.031	754	100.11	22.5
22	.329	.00051	26	.0050	.76	.030	650	86.29	19.4
24	.205	.00032	1	.0201	.61	.024	404	53.63	12.1
24	.227	.00035	7	.0080	.58	.023	448	59.47	13.4
24	.201	.00031	10	.0063	.61	.024	397	52.69	11.8
24	.241	.00037	19	.0050	.58	.023	475	63.06	14.2
24	.200	.00031	41	.0031	.58	.023	394	52.31	11.8
26	.128	.00020	1	.0159	.40	.016	253	33.56	7.5
26	.141	.00022	7	.0063	.53	.021	278	36.88	8.3
26	.127	.00020	10	.0050	.51	.020	250	33.19	7.5
26	.154	.00024	19	.0040	.48	.019	304	40.36	9.1
28	.080	.00012	1	.0126	.32	.013	159	21.08	4.7
28	.089	.00014	7	.0050	.38	.015	175	23.23	5.2
28	.093	.00014	19	.0031	.41	.016	183	24.24	5.4
30	.051	.00008	1	.0100	.25	.010	100	13.28	3.0
30	.057	.00009	7	.0040	.30	.012	112	14.87	3.3
30	.060	.00009	19	.0025	.30	.012	118	15.64	3.5
32	.032	.00005	1	.0080	.20	.008	64	8.50	1.9
32	.034	.00005	7	.0031	.20	.008	67	8.93	2.0
32	.039	.00006	19	.0020	.23	.009	76	10.09	2.3